



 **GOVERNORS**
Line Pressure Regulators

*** APPLICATION NOTES ***

1. The Governor regulator is ANSI Z21.80A-2012 / CSA 6.22A-2012(R2016) and ANSI Z21.18B-2012 / CSA 6.3B-2012 (R2017) certified for vent limited installations (indoor installations where a vent line is not required) depending upon local codes and standards requirements. Per the terminology of the standard there is no "vent less regulator", they are vent limited because they can leak up to 2.5 cu.ft. per hr. (1 cu.ft. per hr. propane) per the code. The regulators per code can be installed without installing a vent line but again are technically termed "vent limited" per the standard not vent less.
2. The tables listed are guidelines in capacity. The actual capacity can differ based on inlet and outlet piping, type of equipment installed and flowing differential pressure of the system.
3. The Governor is a bubble tight full lockup regulator (it will not leak gas downstream when it shuts off). Lock up of the Governor is certified to ANSI Z21.80A-2012 / CSA 6.22A-2012(R2016) and ANSI Z21.18B-2012 / CSA 6.3B-2012 (R2017) standard. Lock up in any given installation can vary based on, piping, snap acting gas valves on high efficiency equipment, firing rate at the time of equipment shut off, debris in the line, temperature, as well as many other variables. You may see variations in lock up in some installations due to the above Pietro Fiorentini will not guarantee the lock up will meet your equipment requirement due to these variations in installations and piping.
4. The low Capacity GOVERNORS 3/8" - 1" are intended for use on equipment such as unit heaters or simple on/off furnace applications.
5. Use the High Capacity GOVERNORS on all "High Efficiency" quick acting gas valve applications, such as generators, pool heaters, or high turn down boilers. Install a regulator on each individual piece of equipment. Size the regulator at minimum 50% to 100% of listed capacity to minimize high lock-up. Make sure you match the regulator pipe size to the pipe size of the equipments gas train and design the piping to minimize pressure drop to 1" W.C. between the regulator and the gas train.
6. Try to match the GOVERNOR regulator to the pipe size of the equipment and minimize pressure drop between the regulator and equipment to 1" W.C.. Minimize the amount of elbows and fittings between the regulator and the equipment and use full port ball valves not plug valves or reduced port valves.
7. Be careful on applications where you increase the outlet piping more than 1 diameter. You may need to install an external control line in the larger piping. The GOVERNOR can be ordered with or retrofitted with an external control line.
8. Make sure on all installations you don't install the regulator directly at the equipment. Install the regulator 3 to 10 feet away depending on the application.
9. Never install the external brass vent limiter outdoors. For outdoors installation install appropriate vent protection.
10. All GOVERNORS include an inlet filter. The filter and/or regulator may be cleaned by removing the bottom plate Torx security screws, bottom plate assembly, then remove the filter. The filter can then be cleaned with detergent or Buna compatible solvent and dried. The valve and orifice can be cleaned with a cloth while the bottom plate is off. Then reassemble the unit.
11. If there are ever any questions on the installation or application of the Governor regulator, immediately contact your local authorized distributor or representative.
12. The maximum inlet pressure on the regulator label is the required maximum pressure of the ANSI Z21.80A-2012 / CSA 6.22A-2012(R2016) and ANSI Z21.18B-2012 / CSA 6.3B-2012 (R2017) rating. It is not always the maximum allowable operating inlet pressure of the regulator. The rating is a CSA requirement.

*** WARRANTY POLICY ***

- 1.** The Seller undertakes to remedy any defects, lack of quality or non conformity of the goods contract for which he is responsible, provided such defects have been notified in accordance within 10 (ten) days from the occurrence. The Seller may either repair or replace the goods which have shown to be defective. In case of repair, request to return product(s) for repair must be pre-approved in writing by our Sales Department. The product(s) shall be returned pre-paid to Pietro Fiorentini USA.
- 2.** Seller is not responsible for defects due to: natural wearing, Buyer's inexperience, negligence, tampering or wrong assemblage, overcome of limits conditions, non authorized intervention, force majeure or fault of the Buyer.
- 3.** The duration of the guarantee is twenty four months from delivery of goods. The present warranty is not enforceable in case of lack of payment in the agreed terms. It is agreed that the obligation to repair or replace the defective goods is in lieu of any other legal guarantee or liability of the Seller, whether contractual or non contractual, which may arise out of or in relation with the goods supplied (e.g.compensation of damages, loss of profit, recall campaigns, etc.). For goods that have been purchased from sub-suppliers, the warranty guarantee granted by them is herewith extended to the Buyer.



INTRODUCTION

Pietro Fiorentini's GOVERNOR line of gas regulators are designed to comply with the latest CSA and international standards for regulators suitable for indoor and outdoor installations with no modifications.

The GOVERNOR family of regulators are ideal for a wide range of residential through large industrial applications. The materials and soft parts used in the construction of the GOVERNOR regulators make them suitable for use with natural gas, LPG, Propane air and other non-corrosive gases.

All GOVERNOR regulators are equipped with balanced valve design for improved high outlet pressure accuracy regardless of Inlet pressure variation. The double diaphragm with integral vent limiter provides added security. The external vent limiter reduces piping costs and the need for costly vent piping for indoor installations and complies with CSA guidelines.* The number of high capacities and regulator options sometimes eliminates the need for separate units and significantly reduces installation costs.

Safe, Reliable and High Performance

- Internal vent limiter: non removable, for indoor and outdoor installations.
- External vent limiter option for indoor installations*.
- Double diaphragm for added safety and greater reliability of service.
- Balanced valve design gives you for increase capacity, high 500 to 1 turndown and stable regulation from low to high flow.
- Complete lockup in absence of gas flow, 100% bubble tight shutoff.
- Filter included in all models.

*As Approved by Local Codes and Standards

** Vent Limiters should be removed for outdoor installation **

MATERIALS

Body & Cover: Aluminum Alloy

External Coatings: Polyurethane paint on request

Diaphragm, O Rings & Valve: Nitrile Rubber

Diaphragm Pan: Aluminized Steel



STANDARD MODEL

Inlet Pressure Range:
3" W.C. to 10PSIG



OVER PRESSURE DEVICE (OPD) MODEL

Inlet Pressure Range:
7" W.C. to 10PSIG



OVER PRESSURE DEVICE (DC) MODEL

Inlet Pressure Range:
3 PSIG to 10 PSIG

PF400 Line Pressure Regulators

Pietro Fiorentini's **PF400** line of gas regulators are designed to comply with the latest **CSA** and international standards for regulators suitable for indoor and outdoor installations with no modifications.

The **PF400** family of regulators are ideal for a wide range of residential through large industrial applications. The materials and soft parts used in the construction of the **PF400** regulators make them suitable for use with **natural gas, LPG, Propane air** and **other non-corrosive** gases.

All **PF400** can achieve high outlet pressure accuracy regardless of Inlet pressure variation. The external vent limiter reduces piping costs and the need for costly vent piping for indoor installations and complies with **CSA** guidelines.*

Safe, Reliable and High Performance

- External vent limiter option for indoor installations*.
- Both vertical and horizontal installation positions
- Complete lockup in absence of gas flow, 100% bubble tight shutoff.
- Designed to be used on furnaces and simple on-off loads. For High efficient equipment use high capacity governors (page 9).

*As Approved by Local Codes and Standards

** Brass Vent Limiters must be removed for outdoor installation **

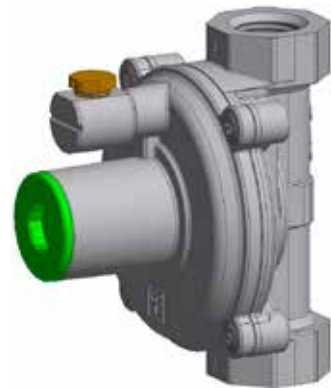

STANDARD MODEL

Inlet Pressure Range: 14" W.C. to 2 PSIG



OVER PRESSURE DEVICE (DC) MODEL

Inlet Pressure Range: 2.5 PSIG to 10 PSIG



PF400S STANDARD MODEL



2 PSIG

MAIN FEATURES

ANSI Z21.80A-2012 / CSA 6.22A-2012(R2016) Class I for outlet pressures up to 14" W.C. Certified
 ANSI Z21.18B-2012 / CSA 6.3B-2012 (R2017) for inlet pressure up to 5 PSI certified
 External Vent Limiter – no vent line required**
 Positive 100% bubble tight lockup
 Filter included in all models

SPECIFICATIONS

Suitable for use with Natural Gas, LPG, and other non-corrosive, clean gas
 Inlet Pressure: 1 PSIG to 2 PSIG CSA approved
 Max. Inlet 10 PSIG for non-CSA applications
 Outlet pressure: 2.5" W.C. to 14" W.C.
 Temperature range: -40°F to 150°F
 Connections: 3/8" and 1/2"
 Maximum Emergency Inlet Exposure Pressure: 65 PSIG
 Suitable for Indoor or Outdoor Installation***

OPTIONS

(VL) Ventlimiter
 (F) Filter

VENT SIZE

1/8" NPT

OUTLET SPRING RANGE

Red 2.5" W.C. to 7" W.C.*
 Black 7" W.C. to 10" W.C.*
 Yellow 10" W.C. to 14" W.C.*
 Blue 0.5 PSIG. to 0.75 PSIG
 Green 0.75 PSIG. to 1.16 PSIG
 Grey 1.16 PSIG. to 1.65 PSIG
 Violet 1.65 PSIG. to 2 PSIG

* Spring is CSA outlet pressure certified
 ** As Approved by Local Codes and Standards

*** Brass vent limiter must be removed for outdoor installation

CAPACITY FOR MULTY-APPLIANCE SERVICE (SCF/H)

Outlet Pressure Set Point		Operating Inlet Pressure					
		1/2 PSI	3/4 PSI	1 PSI	1 1/2 PSI	2 PSI	5 PSI
PF400 1/2"	2.5" W.C.	160	225	300	350	400	400
	7" W.C.	145	200	275	350	400	400
	10" W.C.	110	200	275	350	400	400
	14" W.C.	/	175	250	325	400	400
PF400 3/8"	2.5" W.C.	160	180	200	225	250	250
	7" W.C.	145	180	200	225	250	250
	10" W.C.	110	180	250	275	300	300
	14" W.C.	/	160	200	250	300	300

Tab. 1

Single appliance max capacity 140 SCF/H

Actual stated recommended capacities for optimal performance. For additional sizing, visit www.gasinside.com
 • 888.618.8787

The flow rate with or without filter is the same.

PF400 D DUAL CUT MODEL

10 PSIG

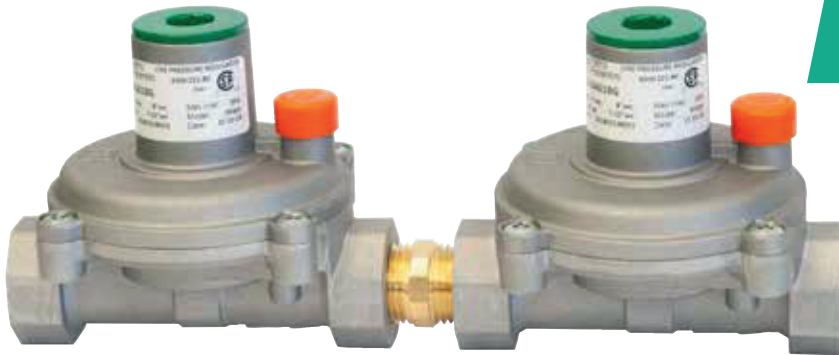
MAIN FEATURES

- 2 stage out for added safety
- ANSI Z21.80A-2012 / CSA 6.22A-2012 (R2016) Class I for outlet pressures up to 14" W.C. and inlet pressure up to 10 PSIG Certified.
- External Vent Limiter – no vent line required**
- Positive 100% bubble tight lockup
- Filter included in all models

SPECIFICATIONS

- Suitable for use with Natural Gas, LPG, and other non-corrosive, clean gas
- Inlet Pressure: 2 PSIG to 10 PSIG CSA approved
- Outlet pressure: 2.5" W.C. to 14" W.C.
- Temperature range: -40°F to 150°F
- Connections: 3/8" and 1/2"
- Maximum Emergency Inlet Exposure Pressure: 65 PSIG
- Suitable for Indoor or Outdoor Installation***

OPTIONS

- (VL) Ventlimiter
- (F) Filter

VENT SIZE

1/8" NPT

OUTLET SPRING RANGE

- Red 2.5" W.C. to 7" W.C.*
- Black 7" W.C. to 10" W.C.*
- Yellow 10" W.C. to 14" W.C.*
- Blue 0.5 PSIG. to 0.75 PSIG
- Green 0.75 PSIG. to 1.16 PSIG
- Grey 1.16 PSIG. to 1.65 PSIG
- Violet 1.65 PSIG. to 2 PSIG

* Spring is CSA outlet pressure certified

** As Approved by Local Codes and Standards

*** Brass vent limiter must be removed for outdoor installation

CAPACITY FOR MULTY-APPLIANCE SERVICE (SCF/H)

Outlet Pressure Set Point	Operating Inlet Pressure			
	3 PSI	5 PSI	10 PSI	
PF400 1/2"	2.5" W.C.	350	400	400
	7" W.C.	350	400	400
	10" W.C.	350	400	400
	14" W.C.	350	400	400
PF400 3/8"	2.5" W.C.	200	250	250
	7" W.C.	250	250	250
	10" W.C.	300	300	300
	14" W.C.	300	300	300

Tab.2

Actual stated recommended capacities for optimal performance.

For additional sizing, visit

www.gasinside.com

• 888.618.8787

The flow rate with or without filter is the same.

Single appliance max capacity 140 SCF/H

GOVERNOR STANDARD MODEL



2^{PSIG}

STANDARD MODEL

Inlet Pressure Range: 3" W.C. to 2 PSIG

MAIN FEATURES

ANSI Z21.80A-2012 / CSA 6.22A-2012(R2016) Class I for outlet pressures up to 14" W.C. Certified

Integral Vent Limiter

External Vent Limiter – no vent line required**

Positive 100% bubble tight lockup

Inlet and Outlet test ports 500 to 1 Turndown

Filter included in all models

SPECIFICATIONS

Suitable for use with Natural Gas,

LPG, and other non-corrosive, clean gas

Inlet Pressure: 3" W.C. to 2 PSIG CSA approved

Max. Inlet 7.25 PSIG for non-CSA applications

Outlet pressure: 2" W.C. to 14" W.C. and up to 4.25 PSIG for non-CSA applications

Temperature range: -40°F to 150°F

Connections: 1/2" thru 4"

Maximum Emergency Inlet Exposure Pressure: 80 PSIG

Suitable for Indoor or Outdoor Installation***

VENT SIZE

1/4" NPT 1/2" – 1"

1/2" NPT 1 1/4" – 4"

OUTLET SPRING RANGE

Green 2" W.C. to 5.1" W.C.*

Red 2.75" W.C. to 7.87" W.C.*

White 4" W.C. to 11.8" W.C.*

Black 6" W.C. to 14" W.C.*

Yellow 9.8" W.C. to 27.5" W.C.*

Violet 23.6" W.C. to 59" W.C. or 0.85 to 2.13

PSIG * Orange 55" W.C. to 118" W.C. or 2 to 4.26 PSIG

* Spring is CSA outlet pressure certified

** As Approved by Local Codes and Standards

*** Brass vent limiter must be removed for outdoor installation

TECHNICAL DATA

Capacity in cfm for .60 Specific gravity gas with filter (capacity without filter in brackets)

	Outlet Pessue Set Point	Operating Inlet Pressure		
		14" W.C.	1 PSIG	2 PSIG
31051 1/2"	8" W.C.	386 (360)	552 (649)	785 (923)
	11" W.C.	218 (256)	511 (601)	785 (923)
31052 3/4"	8" W.C.	369 (450)	665 (812)	946 (1154)
	11" W.C.	363 (321)	616 (751)	946 (1154)
31053 1"	8" W.C.	495 (585)	893 (1,055)	1270 (1154)
	11" W.C.	353 (417)	825 (977)	1270 (1154)
31150 1/2" High Capacity	8" W.C.	610 (855)	1097 (1,543)	1558 (2193)
	11" W.C.	433 (609)	10,14 (1,428)	1558 (2193)
31151 3/4" High Capacity	8" W.C.	714 (1,080)	1284 (1,949)	1824 (2771)
	11" W.C.	507 (770)	1187 (1,803)	1824 (2771)
31152 1" High Capacity	8" W.C.	903 (1,283)	1625 (2,314)	2309 (3290)
	11" W.C.	642 (914)	1503 (2,142)	2309 (3290)
31153 1 1/4"	8" W.C.	2,071(3,062)	3,735 (5,522)	5311 (7851)
	11" W.C.	1,476 (2,183)	3,457 (5,110)	5311 (7851)
31154 1 1/2"	8" W.C.	2,567 (3,197)	4,629 (5,766)	6581 (8197)
	11" W.C.	1,829 (2,279)	4,284 (5,336)	6581 (8197)
31155 2"	8" W.C.	5,179 (5,854)	9,339 (10,557)	13278 (15009)
	11" W.C.	3,691(4,173)	8,643 (9,336)	13278 (15009)
31156/F 2 1/2"	8" W.C.	6,530 (7,431)	11,775 (13,999)	16741(19051)
	11" W.C.	4,655 (5,297)	10,898 (12,401)	16741(19051)
31157/F 3"	8" W.C.	7,205 (9,007)	12,993 (16,242)	18473 (23092)
	11" W.C.	12,025 (6,240)	12,025 (15,032)	18473 (23092)
31158/F 4"	8" W.C.	12,835 (15,762)	23,245 (28,424)	32906 (40411)
	11" W.C.	9,149 (11,236)	21,420 (26,306)	32906 (40411)

Tab.3

For additional sizing, visit www.gasinside.com www.GasInside.com • 888.618.8787



GOVERNOR OVER PRESSURE DEVICE (OPD) MODEL



10^{PSIG}

OVER PRESSURE DEVICE (OPD) MODEL

Inlet Pressure Range: 7" W.C. to 10 PSIG

MAIN FEATURES

Worker & Monitor for added Safety
ANSI Z21.80A-2012 / CSA 6.22A-2012(R2016) Class I
and Class II for outlet pressures up to 14" W.C. and inlet
pressures up to 10 PSIG Certified
Integral Vent Limiter
External Vent Limiter – no vent line required**
Positive 100% bubble tight lockup Inlet and Outlet test
ports 500 to 1 Turndown
Filter included in all models

SPECIFICATIONS

Suitable for use with Natural Gas, LPG, and other non-
corrosive, clean gas
Inlet Pressure: 7" W.C. to 10 PSIG CSA approved
Max. Inlet 10 PSIG for non-CSA applications
Outlet pressure: 2" W.C. to 1" W.C. and up to 4.25 PSIG
Temperature range: -40°F to 150°F
Connections: ½" thru 4"
Maximum Emergency Inlet Exposure Pressure: 80 PSIG
Suitable for Indoor or Outdoor Installation

VENT SIZE

1/4" NPT 1/2" – 1"
1/2" NPT 1 1/4" – 4"

OUTLET SPRING RANGE

Green 2" W.C. to 5.1" W.C.*
Red 2.75" W.C. to 7.87" W.C.*
White 4" W.C. to 11.8" W.C.*
Black 6" W.C. to 14" W.C.*
Yellow 9.8" W.C. to 27.5" W.C.*
Violet 23.6" W.C. to 59" W.C. or 0.85 to 2.13
PSIG * Orange 55" W.C. to 118" W.C. or 2 to
4.26 PSIG

- * Spring is CSA outlet pressure certified
- ** As Approved by Local Codes and Standards
- *** Brass vent limiter must be removed for outdoor installation

TECHNICAL DATA

CAPACITY IN CFH FOR .60 SPECIFIC GRAVITY GAS WITH FILTER (CAPACITY WITHOUTH FILTER IN BRACKETS)

Outlet Pessue Set Point		Operating Inlet Pressure		
		3 PSIG	5 PSIG	10 PSIG
31051OPD ½"	8" W.C.	785 (923)	785 (923)	785 (923)
	11" W.C.	785 (923)	785 (923)	785 (923)
	14" W.C.	785 (923)	785 (923)	785 (923)
31052OPD ¾"	8" W.C.	946 (1154)	946 (1154)	946 (1154)
	11" W.C.	946 (1154)	946 (1154)	946 (1154)
	14" W.C.	946 (1154)	946 (1154)	946 (1154)
31053OPD 1"	8" W.C.	1270 (1500)	1270 (1500)	1270 (1500)
	11" W.C.	1270 (1500)	1270 (1500)	1270 (1500)
	14" W.C.	1270 (1500)	1270 (1500)	1270 (1500)
31150OPD ½" High Capacity	8" W.C.	1558 (2193)	1558 (2193)	1558 (2193)
	11" W.C.	1558 (2193)	1558 (2193)	1558 (2193)
	14" W.C.	1558 (2193)	1558 (2193)	1558 (2193)
30151OPD ¾" High Capacity	8" W.C.	1824 (2771)	1824 (2771)	1824 (2771)
	11" W.C.	1824 (2771)	1824 (2771)	1824 (2771)
	14" W.C.	1824 (2771)	1824 (2771)	1824 (2771)
31152 OPD 1"	8" W.C.	2309 (3290)	2309 (3290)	2309 (3290)
	11" W.C.	2309 (3290)	2309 (3290)	2309 (3290)
	14" W.C.	2309 (3290)	2309 (3290)	2309 (3290)
31153 OPD 1¼"	8" W.C.	5311 (7851)	5311 (7851)	5311 (7851)
	11" W.C.	5311 (7851)	5311 (7851)	5311 (7851)
	14" W.C.	5311 (7851)	5311 (7851)	5311 (7851)
31154OPD 1 ½"	8" W.C.	6581 (8197)	6581 (8197)	6581 (8197)
	11" W.C.	6581 (8197)	6581 (8197)	6581 (8197)
	14" W.C.	6581 (8197)	6581 (8197)	6581 (8197)
31155OPD 2"	8" W.C.	13278 (15009)	13278 (15009)	13278 (15009)
	11" W.C.	13278 (15009)	13278 (15009)	13278 (15009)
	14" W.C.	13278 (15009)	13278 (15009)	13278 (15009)
31156OPD 2½"	8" W.C.	16741 (19741)	16741 (19741)	16741 (19741)
	11" W.C.	16741 (19741)	16741 (19741)	16741 (19741)
	14" W.C.	16741 (19741)	16741 (19741)	16741 (19741)
31157OPD 3"	8" W.C.	18473 (23092)	18473 (23092)	18473 (23092)
	11" W.C.	18473 (23092)	18473 (23092)	18473 (23092)
	14" W.C.	18473 (23092)	18473 (23092)	18473 (23092)
31158OPD 4"	8" W.C.	32906 (40411)	32906 (40411)	32906 (40411)
	11" W.C.	32906 (40411)	32906 (40411)	32906 (40411)
	14" W.C.	32906 (40411)	32906 (40411)	32906 (40411)

Tab.4

 For additional sizing, visit www.gasinside.com www.GasInside.com • 888.618.8787

OVER PRESSURE DEVICE (DC) MODEL



OVER PRESSURE DEVICE (DC) MODEL

Inlet Pressure Range: 3" PSIG to 10 PSIG

MAIN FEATURES

- 2 stage out for added Safety
- ANSI Z21.80A-2012 / CSA 6.22A-2012(R2016) Class I and Class II for outlet pressures up to 14" W.C. and inlet pressures up to 10 PSIG Certified
- Two stage regulation for Over Pressure Protection
- Integral Vent Limiter
- External Vent Limiter – no vent line required**
- Positive 100% bubble tight lockup Inlet and Outlet test ports 500 to 1 Turndown
- Filter included in all models

SPECIFICATIONS

- Suitable for use with Natural Gas, LPG, and other non-corrosive, clean gas
- Inlet Pressure: 3 PSIG to 10 PSIG
- Max. Inlet 10 PSIG for CSA and non-CSA applications
- Outlet pressure: 2" W.C. to 1 PSIG for CSA and up to 3 PSIG for non-CSA applications
- Temperature range: -40°F to 150°F
- Connections: 1/2" thru 4"
- Maximum Emergency Inlet Exposure Pressure: 80 PSIG
- Suitable for Indoor or Outdoor Installation

10^{PSIG}

VENT SIZE

- 1/4" NPT 1/2" – 1"
- 1/2" NPT 1 1/4" – 4"

OUTLET SPRING RANGE

- Green 2" W.C. to 5.1" W.C.*
- Red 2.75" W.C. to 7.87" W.C.*
- White 4" W.C. to 11.8" W.C.*
- Black 6" W.C. to 14" W.C.*
- Yellow 9.8" W.C. to 27.5" W.C.*
- Violet 23.6" W.C. to 59" W.C. or 0.85 to 2.13 PSIG * Orange 55" W.C. to 118" W.C. or 2 to 4.26 PSIG

- * Spring is CSA outlet pressure certified
- ** As Approved by Local Codes and Standards
- *** Brass vent limiter must be removed for outdoor installation

TECHNICAL DATA

CAPACITY IN CFH FOR .60 SPECIFIC GRAVITY GAS WITH FILTER (CAPACITY WITHOUTH FILTER IN BRACKETS)

Outlet Pessue Set Point		Operating Inlet Pressure		
		3 PSIG	5 PSIG	10 PSIG
31051OPD ½"	8" W.C.	785 (923)	785 (923)	785 (923)
	11" W.C.	785 (923)	785 (923)	785 (923)
	14" W.C.	785 (923)	785 (923)	785 (923)
31052OPD ¾"	8" W.C.	946 (1154)	946 (1154)	946 (1154)
	11" W.C.	946 (1154)	946 (1154)	946 (1154)
	14" W.C.	946 (1154)	946 (1154)	946 (1154)
31053OPD 1"	8" W.C.	1270 (1500)	1270 (1500)	1270 (1500)
	11" W.C.	1270 (1500)	1270 (1500)	1270 (1500)
	14" W.C.	1270 (1500)	1270 (1500)	1270 (1500)
31150OPD ½" High Capacity	8" W.C.	1558 (2193)	1558 (2193)	1558 (2193)
	11" W.C.	1558 (2193)	1558 (2193)	1558 (2193)
	14" W.C.	1558 (2193)	1558 (2193)	1558 (2193)
30151OPD ¾" High Capacity	8" W.C.	1824 (2771)	1824 (2771)	1824 (2771)
	11" W.C.	1824 (2771)	1824 (2771)	1824 (2771)
	14" W.C.	1824 (2771)	1824 (2771)	1824 (2771)
31152 OPD 1"	8" W.C.	2309 (3290)	2309 (3290)	2309 (3290)
	11" W.C.	2309 (3290)	2309 (3290)	2309 (3290)
	14" W.C.	2309 (3290)	2309 (3290)	2309 (3290)
31153 OPD 1¼"	8" W.C.	5311 (7851)	5311 (7851)	5311 (7851)
	11" W.C.	5311 (7851)	5311 (7851)	5311 (7851)
	14" W.C.	5311 (7851)	5311 (7851)	5311 (7851)
31154OPD 1 ½"	8" W.C.	6581 (8197)	6581 (8197)	6581 (8197)
	11" W.C.	6581 (8197)	6581 (8197)	6581 (8197)
	14" W.C.	6581 (8197)	6581 (8197)	6581 (8197)
31155OPD 2"	8" W.C.	13278 (15009)	13278 (15009)	13278 (15009)
	11" W.C.	13278 (15009)	13278 (15009)	13278 (15009)
	14" W.C.	13278 (15009)	13278 (15009)	13278 (15009)
31156OPD 2½"	8" W.C.	16741 (19741)	16741 (19741)	16741 (19741)
	11" W.C.	16741 (19741)	16741 (19741)	16741 (19741)
	14" W.C.	16741 (19741)	16741 (19741)	16741 (19741)
31157OPD 3"	8" W.C.	18473 (23092)	18473 (23092)	18473 (23092)
	11" W.C.	18473 (23092)	18473 (23092)	18473 (23092)
	14" W.C.	18473 (23092)	18473 (23092)	18473 (23092)
31158OPD 4"	8" W.C.	32906 (40411)	32906 (40411)	32906 (40411)
	11" W.C.	32906 (40411)	32906 (40411)	32906 (40411)
	14" W.C.	32906 (40411)	32906 (40411)	32906 (40411)

Tab.4

 For additional sizing, visit www.gasinside.com www.GasInside.com • 888.618.8787

STANDARD MODEL DIMENSIONS

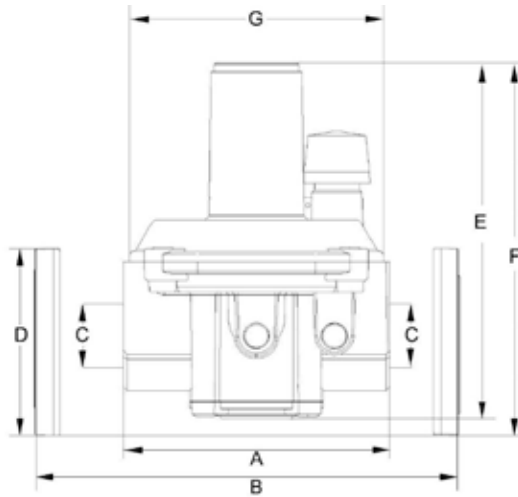

Model	Size	A	B	C	D	E	F	G*	Weight (Lbs)
PF400S	3/8 NPT	3.90	-	3/8	-	3.42	-	3.10	0.56
PF400S	1/2" NPT	3.90	-	1/2	-	3.42	-	3.10	0.56
31051	1/2" NPT	4.09	-	1/2	-	5.59	-	3.78	1.54
31052	3/4" NPT	4.09	-	3/4	-	5.59	-	3.78	1.54
31053	1" NPT	4.09	-	1	-	5.59	-	3.78	1.54
31150	1/2" NPT	4.72	-	1/2	-	6.89	-	4.49	2.75
31151	3/4" NPT	4.72	-	3/4	-	6.89	-	4.49	2.75
31152	1" NPT	4.72	-	1	-	6.89	-	4.49	2.75
31153	1 1/4" NPT	7.68	-	1 1/4	-	10	-	7.56	7.5
31154	1 1/2" NPT	7.68	-	1 1/2	-	10	-	7.56	7.5
31155	2" NPT	9.29	-	2	-	12.44	13.74	7.56	12.34
31156/F	2 1/2" FLANGED	-	16.9	3	ANSI 150	-	17.09	12.52	27.56
31157/F	3" FLANGED	-	16.9	3	ANSI 150	-	17.09	12.52	27.56
31158/F	4" FLANGED	-	16.9	4	ANSI 150	-	19.76	12.52	27.56

Tab.6

* (G) Dimensions is the width of the regulator

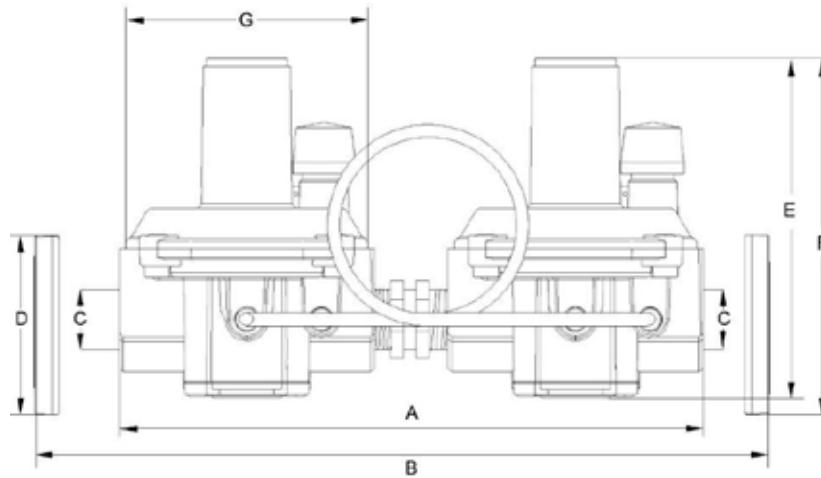
OVER PRESSURE DEVICE (DC or OPD) MODEL DIMENSIONS

Model	Size	A	B	C	D	E	F	G*	Weight (Lbs)
PF400D	3/8 NPT	8.40	-	3/8	-	3.42	-	3.10	1.18
PF400D	1/2" NPT	8.50	-	1/2	-	3.42	-	3.10	1.20
31051	1/2" NPT	8.46	-	1/2	-	5.59	-	3.78	3.25
31052	3/4" NPT	8.46	-	3/4	-	5.59	-	3.78	3.25
31053	1" NPT	8.46	-	1	-	5.59	-	3.78	3.25
31150	1/2" NPT	10.10	-	1/2	-	6.89	-	4.49	5.75
31151	3/4" NPT	10.10	-	3/4	-	6.89	-	4.49	5.75
31152	1" NPT	10.10	-	1	-	6.89	-	4.49	5.75
31153	1 1/4" NPT	16.69	-	1 1/4	-	10	-	7.56	15.5
31154	1 1/2" NPT	16.69	-	1 1/2	-	10	-	7.56	15.5
31155	2" NPT	19.88	-	2	-	12.44	13.74	7.56	25
31156/F	2 1/2" FLANGED	-	33.93	3	ANSI 150	-	17.09	12.52	56
31157/F	3" FLANGED	-	33.93	3	ANSI 150	-	17.09	12.52	56
31158/F	4" FLANGED	-	33.93	4	ANSI 150	-	19.76	12.52	56

Tab.7

* (G) Dimensions is the width of the regulator

www.fiorentini.com
www.gasinside.com

The data are not binding. We reserve the right to make changes without prior notice.

